

# SteelNor

## SS605DD Continuous Web Sealer

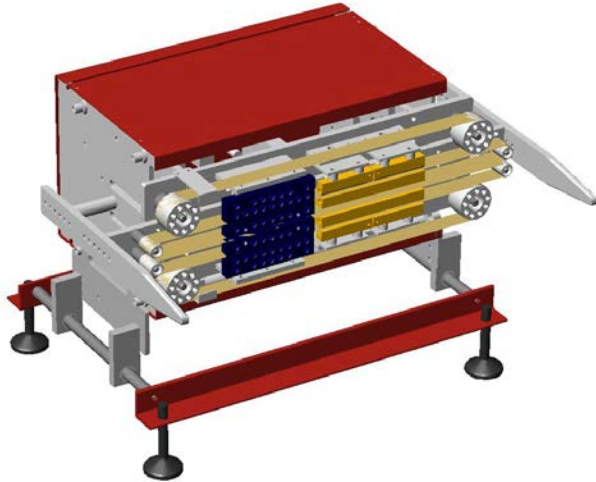

The SS605DD **Continuous Web Sealer** is designed and specifically used for **fold over top material**.

### **Product Features:**

- Main chassis construction from aluminium and stainless steel.
- Twin sealing sections separated by adjustable film guide bars.
- Fully adjustable sealing shoes allow the contact angle and pressure to be set to your needs.
- Capable of sealing up to 6" into the web.
- Laboratory quality, solid-state temperature controls for both upper and lower heating zones.
- Triple Cooling Blowers, the center blower is independently switched to alleviate film inflation in certain applications.
- Onboard pneumatic valve to close sealing jaws when running and open to prevent scorching when idle.
- A web path of any angle is accommodated with the adjustable floor pads or easy mounting points.
- Stainless Steel Covers.
- A variety of seal widths are available from 1/8" to 7/16".
- Base stand allows for easy fine-tuning of the seal position.
- Operates on standard 120 VAC and 60-psi shop air.

### **Product Options Available:**

- Chilled Liquid or Air Cooling.
- Custom mounting brackets for operation in a vertical direction.

*SteelNor*, products manufactured by Inventure Engineering & Machinery

511 Welham Rd., Barrie, Ont., L4N 8Z6 Canada

V: (705) 725-9750 - F: (705) 725-8086

Web: <http://www.steelnor.com> E-Mail: [pack@steelnor.com](mailto:pack@steelnor.com)

\* Specifications Subject To Change Without Notice